

LAYOUT PLAN

Layout plan 30 deg.

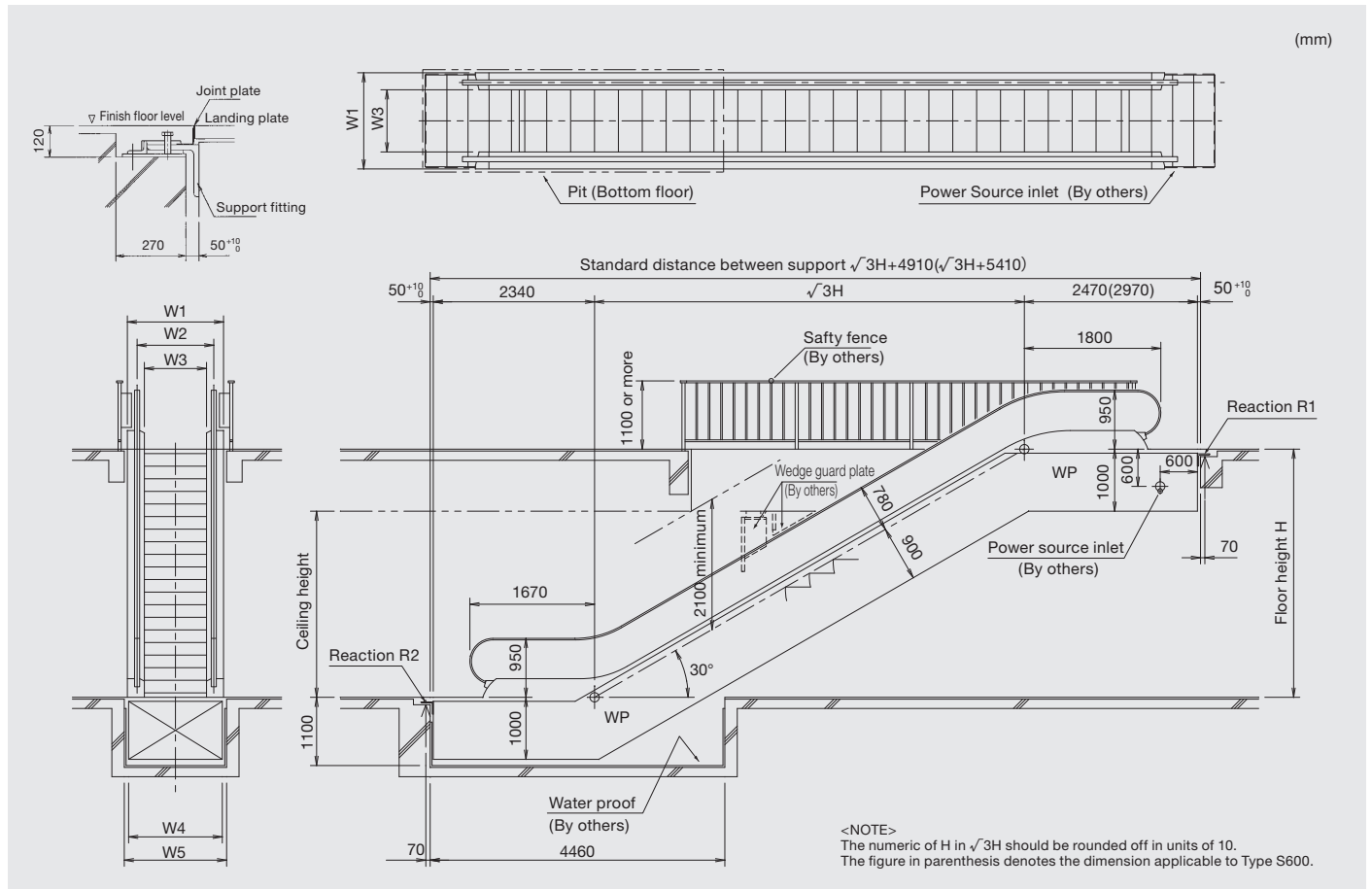

Dimensions(mm)

Type	S600	S800	S1000
W1	1150	1350	1550
W2	836	1036	1236
W3	603	802	1002
W4	1110	1310	1510
W5	1250	1450	1650

Reaction(N)

Type	S600	S800	S1000
Floor height (mm)	$H \leq 6000$	$H \leq 6000$	$H \leq 6000$
R1	$6.96H+30500$	$8.15H+33500$	$9.35H+36500$
R2	$6.96H+26500$	$8.15H+29500$	$9.35H+32500$

Explanation of safety devices

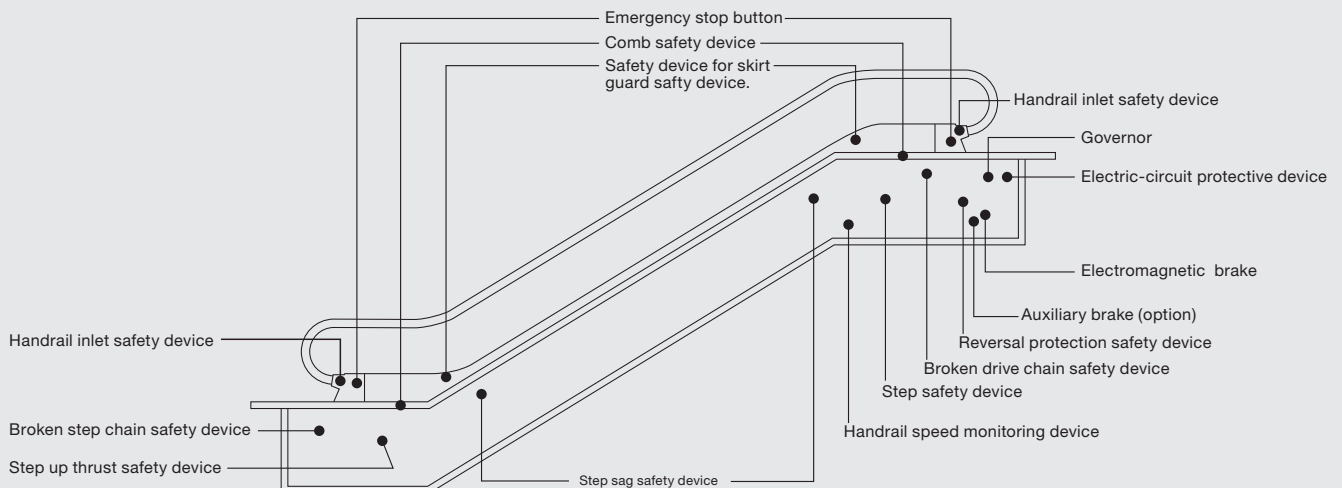

LAYOUT PLAN

Layout plan 35 deg.

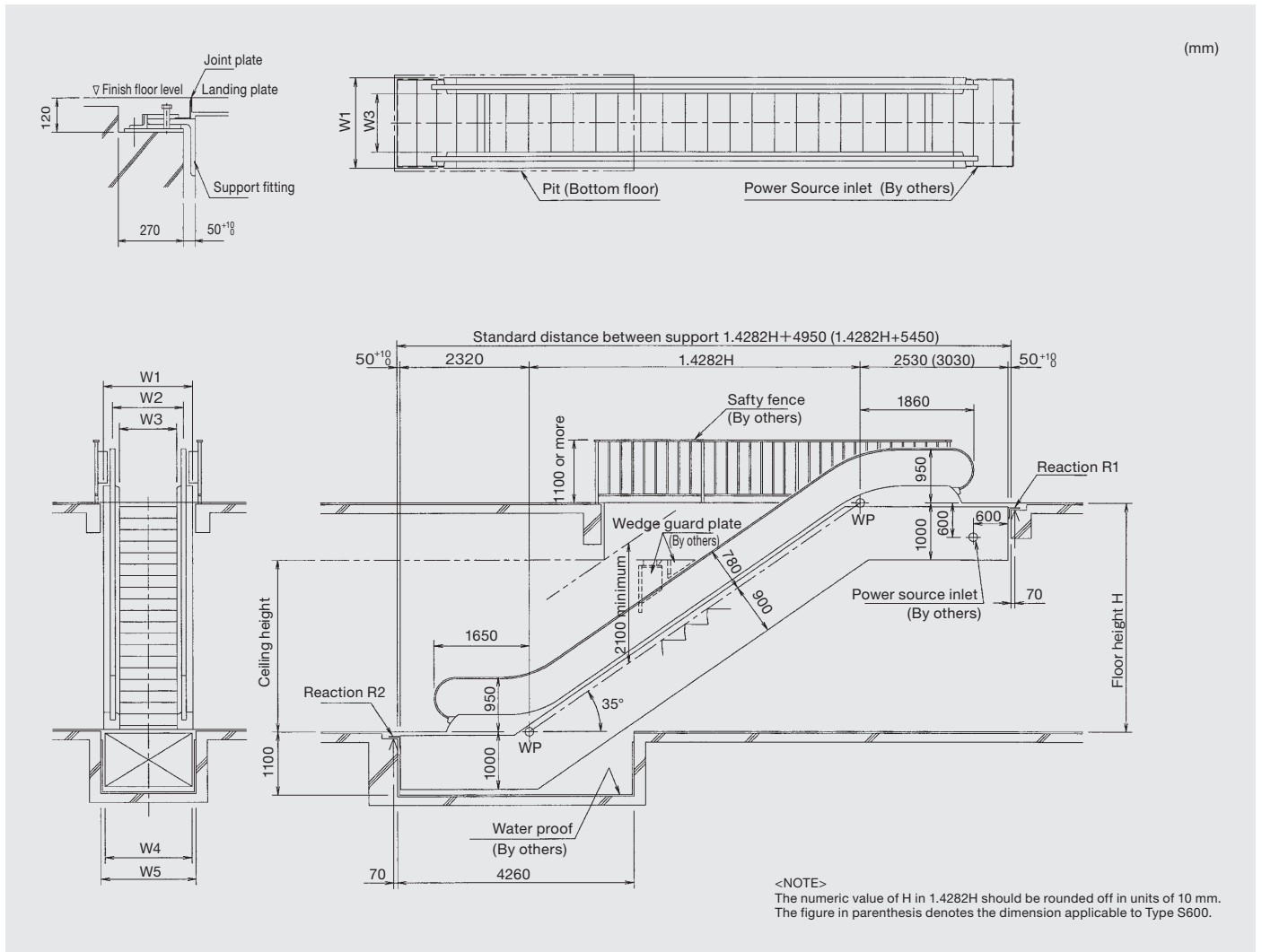

Dimensions(mm)

Type	S600	S800	S1000
W1	1150	1350	1550
W2	836	1036	1236
W3	603	802	1002
W4	1110	1310	1510
W5	1250	1450	1650

Reaction(N)

Type	S600	S800	S1000
Floor height (mm)	$H \leq 6000$	$H \leq 6000$	$H \leq 6000$
R1	$5.85H + 30000$	$6.85H + 33000$	$7.85H + 36000$
R2	$5.85H + 27000$	$6.85H + 30000$	$7.85H + 33000$